



Maximize your revenue stream across a wide range of small commercial applications with the Intermediate MS Multi-Jet, and capture low flow usage where turbine meters fall short.

### Technical Specifications:

- **AWWA Standard** - Meets or exceeds all sections of Standard ANSI / AWWA C708, most recent revision for cold water multi-jet meters.
- **Design/Operation** - Velocity-type flow measurement. Water is evenly distributed by multiple converging inlet ports flows past an impeller in the measuring chamber, creating an impeller velocity directly proportional to water flow rate. The meter's register integrates that velocity into totalized flow.
- **Main Case** - Meets NSF/ ANSI 372 / NSF 61 Standards and is compliant with the Safe Drinking Water Act (SDWA). Lead free waterworks bronze case made of 86% minimum copper composition. Body design incorporates either compact externally threaded ends, or bolted, oval flanged connections. Top load bolted design.
- **Magnetic Drive** - A reliable, direct magnetic drive provides linkage between measurement element and register. No intermediate gearing is required; no gearing is exposed to water.

### Features & Benefits:

- 'MS' design with enhanced basket strainer and top load body provides exceptionally low head loss and improved reliability over the life of the meter.
- Precise Low Flow Accuracy to enhance water accountability.
- Meter performance exceeds the AWWA C-708 Standards in the critical areas of head loss and accuracy.
- Provides exceptional capabilities for passing entrained solids and operating in environments with high mineral content.
- Flexible application-specific vacuum sealed registers including Direct Read, AccuLinx Encoder, 3G AMR/AMI, Interpreter and IP68+ Pulse Output are available on MS Multi-Jet meters.
- Precision Engineered Flow Components and a Computational Fluid Dynamic (CFD) optimized design produces a smooth, balanced flow profile for improved, sustained accuracy and optimized revenue under the toughest conditions.



**Technical Specs (Cont'd):**

- **Register** - All Master Meter registers are vacuum sealed with a scratch resistant, tempered glass lens, stainless steel base and wrap-around gasket to prevent intrusion of dirt or moisture. The register assembly is removable under line pressure permitting seamless, simplified upgrades in reading technology. Available in USG, CF or M<sup>3</sup>. Solid-state (LCD) registers come equipped with meter flow rate and flow direction arrows to determine real-time flow and potential leaks. Direct Read registers come equipped with center mounted low flow leak indicator with high sensitivity resulting from direct one to one linkage to measuring element and large center sweep hand with one hundred (100) clearly marked gradations on the periphery of the dial face.
- **Measuring Chamber** - The measuring chamber housing and measurement element are built with an

advanced synthetic polymer. Measurement surfaces are not wear surfaces, providing sustained accuracy despite the presence of entrained solids in the water. A long-life, synthetic sapphire bearing serves as a wear surface. The chamber housing is constructed in two parts to allow access to the impeller.

- **Strainer** - A rugged, 360° basket strainer built from advanced polymer materials for superior wear mitigation protecting critical measuring element from damage. The unique strainer design smoothes the flow of water entering into the meter creating a balanced flow that is gentle on the meter's internal components.
- **Tamper Detection** - The Master Meter Multi-Jet adjusting port and register are concealed to prevent tampering and removal of the register. This design also provides a visual indication of tampering attempts.

**Accuracy Charts**

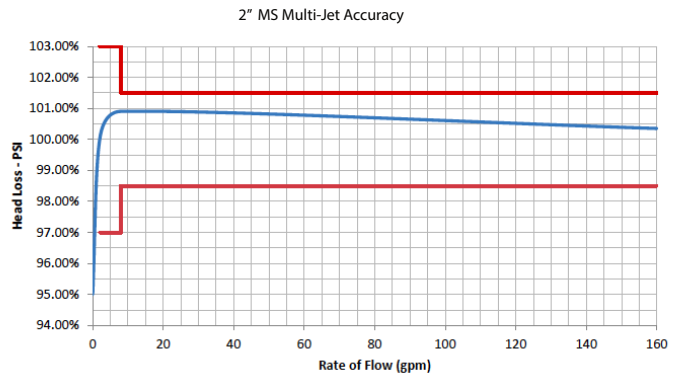
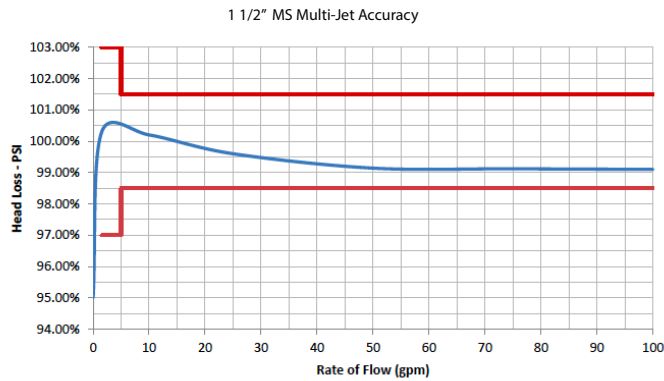

\* For expanded head loss and accuracy charts please see Engineering Charts, Version 8.13.

**Performance Data**

METER OPERATING CHARACTERISTIC/DIMENSION	1 1/2" Threaded	1 1/2" Flanged	2" Threaded	2" Flanged
Flow Rating (gpm)	100	100	160	160
Continuous Flow (gpm)	75	75	120	120
Normal Flow Range (gpm) Accuracy 98.5% - 101.5%	5-100	5-100	8-160	8-160
Low Flow (gpm) Accuracy 97% - 103%	1.5	1.5	2	2
Maximum Working Pressure (psi)	150	150	150	150
Maximum Working Temperature (°F)	120	120	120	120
Length	12 3/8"	13"	15 1/4"	17"
Width	5 3/4"	5 3/4"	5 3/4"	5 3/4"
Height, standard register with lid	6 3/4"	6 3/4"	7 7/8"	7 7/8"
Height with DIALOG register	7 1/2"	7 1/2"	8 3/4"	8 3/4"
Height, bottom to center line	1 3/4"	1 1/2"	2 1/4"	2 1/4"
Meter Casing Spuds, Nominal Threadsize	2"	N/A	2 1/2"	N/A
Weight (lbs)	11	12	20	24
Packed To Carton	1	1	1	1
Carton Weight (lbs)	12	14	22	26

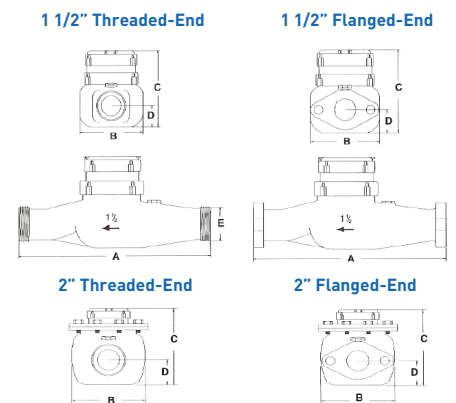

v0928.21F